

Installation Manual

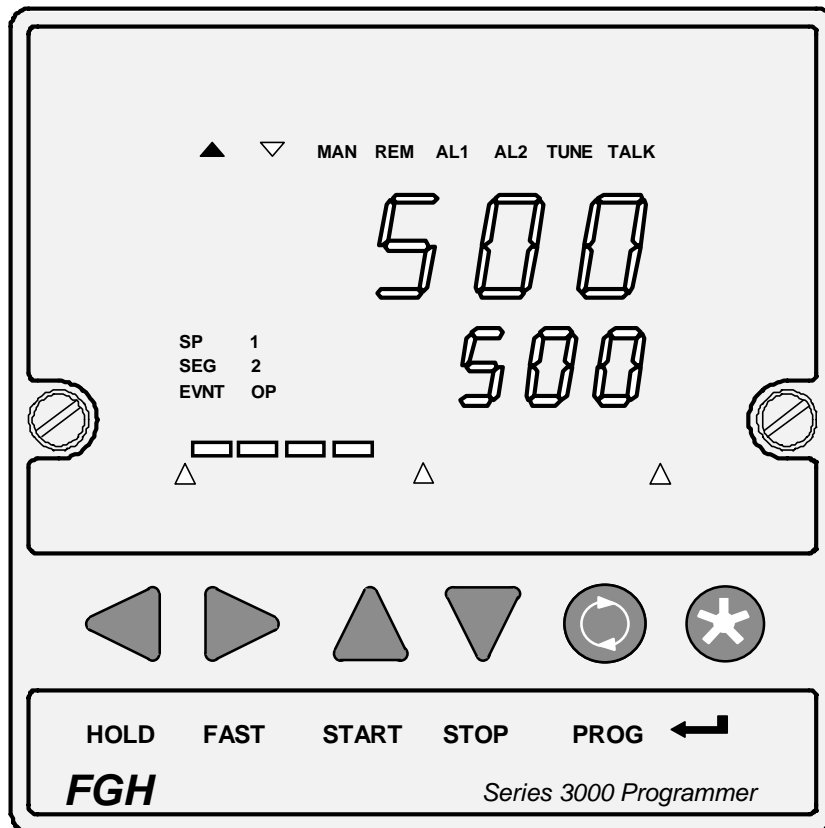

Series 3000

FGH Controls Ltd
Openshaw Way, Letchworth
Herts. SG6 3ER
Tel: (01462) 686677
Fax: (01462) 480633

Contents

1.0 INTRODUCTION	2
2.0 WARNING NOTES.....	2
3.0 MECHANICAL	2
3.1 Instrument sealing.....	3
4.0 INPUT CONNECTIONS	4
4.1 Power Supply	4
4.1.1 Mains Power Supply	4
4.1.2 24V to 48V DC Power supply	5
4.2 Temperature sensor.....	5
4.2.1 Low level voltage input.....	5
4.2.2 High level current (20mA) input.	5
4.2.3 High level voltage input.....	6
4.3 Remote setpoint.....	6
4.4 Digital inputs.....	6
4.5 Slidewire input.....	6
4.6 Remote Program Select Input (P3000 Only).....	6
5.0 OUTPUT CONNECTIONS.....	7
5.1 Heat/Cool	7
5.2 Motorised valve	8
5.3 Alarms	8
5.4 Retransmission	9
5.5 Transmitter power supply.....	9
5.6 Event output (P3000 only)	9
5.7 External event driver (P3000 only).....	10
6.0 COMMUNICATIONS.....	10
7.0 TERMINAL LEGENDING.....	10

1.0 INTRODUCTION

This manual covers the unpacking, panel mounting and connecting of the FGH P3000 programmer and S3000 process controller.

Other useful information is to be found in the following tomes
 Series 3000 Operators Manual.
 Series 3000 Engineers Manual.
 Series 3000 Communications Manual.

2.0 WARNING NOTES.

WARNING

Fit a policeman. Should people be put in danger if your heating process goes out of control then you must fit a separate over-temperature trip. Wire this trip, or policeman, to turn off the heater if the process gets too hot or the policeman fails.

This may come about as a result of equipment failure, unauthorised tampering or any of a number of other reasons. It is also a good idea to fit a policeman so that 'out of control' heating will not damage the plant itself or its contents. For a suitable policeman contact FGH Controls Ltd.

Note! Always provide the policeman with it's own independent temperature sensor.

3.0 MECHANICAL

The instrument will fit into a DIN standard 92mm x 92mm +0.8mm -0 square cut-out and will accommodate a panel thickness up to 15mm.

The instrument projects behind the panel by less than 148mm, or by less than 150mm when the terminal cover provided is fitted. It is recommended that the terminal cover provided is used, as this provides a degree of electrical safety.

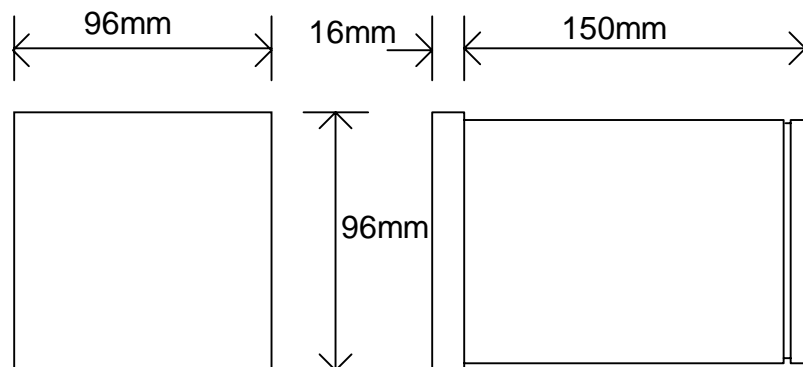

PANEL CUTOUT

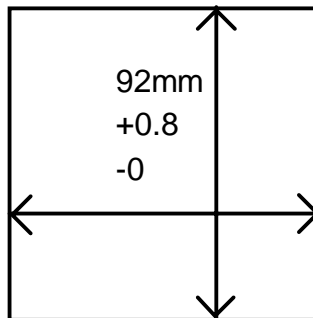

To fit the instrument into a panel first remove the controller/programmer from its sleeve by undoing the two screws on the front panel. This will cause the front of the instrument to separate from the body. When fully undone the bezel, complete with boards attached, may be withdrawn from the instrument case.

You will now see two screws at the top and bottom of the front of the instrument case. These should be undone in an anticlockwise direction. This will cause the retaining ears to locate in the recess provided and travel backwards in this recess to allow for panel thickness.

If IP65 sealing is required then the gasket provided must be fitted now. See 'Instrument Sealing' below.

If IP65 sealing is not required then the gasket is not required and the instrument case may now be inserted through the panel cut-out

Hold the case against the panel and turn the two screws clockwise so that the retaining ears turn out from the case. continue to do up the screws until the instrument case is clamped against the panel. Do not over tighten.

3.1 Instrument sealing

Each instrument is provided with a sealing gasket in a separate bag. This is used to seal the instrument bezel against the mounting panel to achieve sealing to the IP65 standard. To use this gasket, remove it from its bag and flex it gently to detach the gasket from its former. One side of the gasket is self adhesive, so remove the paper cover from the gasket and place the gasket sticky side first over the body of the instrument before fitting the instrument to the panel. Take care to place the gasket squarely around the bezel of the instrument before sticking it down.

The instrument may now be fitted into the panel as described by the installation instructions above

Additional measures will be required to seal multiple instruments if they are mounted in a common slot. These measures may consist of sealing compound or other devices at the discretion of the installer.

4.0 INPUT CONNECTIONS

WARNING.

ISOLATE THE INSTRUMENT FROM MAINS VOLTAGE BEFORE REMOVING THE TERMINAL COVER TO GUARD AGAINST ELECTRIC SHOCK. TAKE PARTICULAR CARE TO ISOLATE FROM HIGH VOLTAGES WHICH MAY HAVE BEEN CONNECTED TO THERMOCOUPLE, ALARM RELAYS ETC.

All connections are made to the instrument at the rear terminal block. To gain access to the terminals, undo the single captive screw in the rear terminal cover.

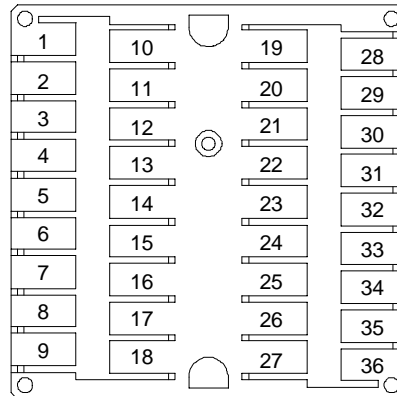

Ensure that mains power wiring is routed separately to sensor and low voltage signal wiring. This is to avoid electrical noise affecting the controllers performance. Never run these two groups of cables together in the control cabinet or anywhere in the plant.

4.1 Power Supply

4.1.1 Mains Power Supply

Power supply 85v to 264v AC is connected to terminals 2 and 3.

EARTH is connected to terminals 1 and 36. This is safety earth and is connected to the metal case of the instrument.

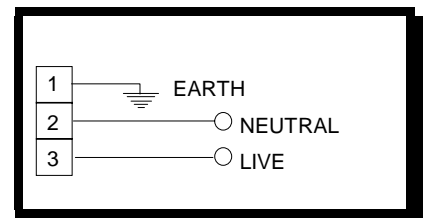

4.1.2 24V to 48V DC Power supply

The DC power supply (24V to 48V) is connected to terminals 2 (PWR -) and 3 (PWR +) and is internally fused at 500mA.

A good earth should also be connected to terminal 1 and 36 as for the AC power version.

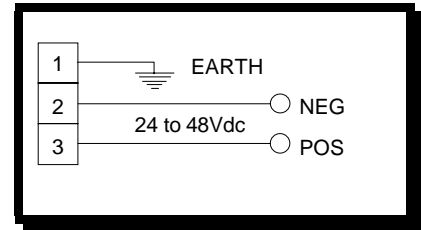

WARNING.

Instruments designed for use on DC power supplies will be damaged if connected to 110-240V AC supplies.

4.2 Temperature sensor

Thermocouple connection via compensating cable of the correct type is made to terminal (IN 1) 7 (+ve) and (IN 2) 8 (-ve). Make a link between (IN 2) 8 and (IN 3) 9.

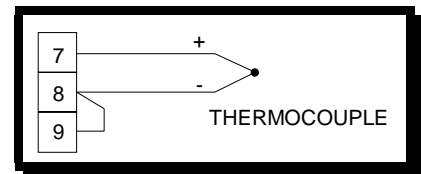

A resistance thermometer may be connected in a three wire bridge as follows. Take terminal (IN 1) 7 to one side of the resistance thermometer. Take the other side of the RT via two separate wires, to terminals (IN 2) 8 and (IN 3) 9. All three wires should be of the same gauge and length. Twist the wires together to reduce the effect of mains noise.

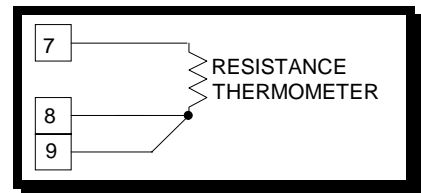

4.2.1 Low level voltage input

Input signals in the range 0 to 90mV may be connected directly to the instrument as shown; positive to (IN 1) pin 7, negative to (IN 2) pin 8 and connect a link between (IN 2) pin 8 and (IN 3) pin 9.

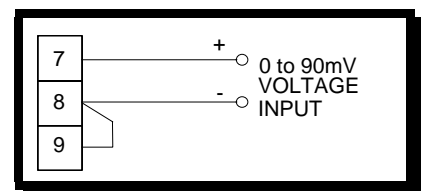

4.2.2 High level current (20mA) input.

For 20mA current inputs, a 4.5 Ω shunt resistor is fitted internally between terminals 10 and 12. The incoming current signal should be connected to terminals 10 (positive) and 12 (negative) and two additional wires should be fitted to connect terminals 10 and 7, and terminals 12 and 8.

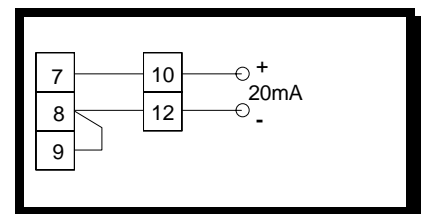

4.2.3 High level voltage input.

For high level voltage inputs or non standard current inputs an external signal conditioning board is supplied. This provides the necessary shunts or dividing components to convert from the high level input signal down to the 0 to 90mV signal required by the instrument.

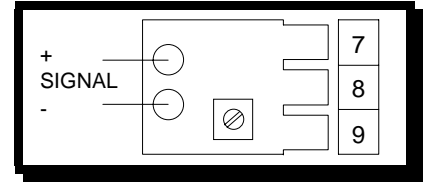

4.3 Remote setpoint

A remote setpoint card may be fitted to slot 5. This may be a $\pm 1V$, $\pm 10V$ or 20mA signal and is connected to terminals (RSP +) 26 and (RSP -) 25 as shown on the label attached to the instrument. This input is scaled in software.

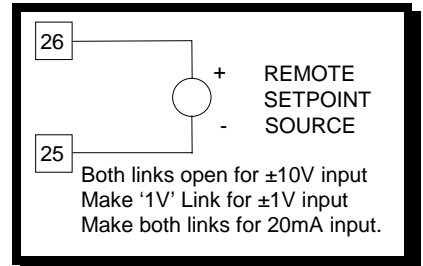

4.4 Digital inputs

All P3000 and S3000 versions accept two digital inputs for use as process HOLD, LOCK etc. as configured by software. DIGITAL input 1 is connected to terminal (DI-1) 5 and input 2 connected to terminal (DI-2) 6. The common for both inputs is terminal (DI-COM) 4.

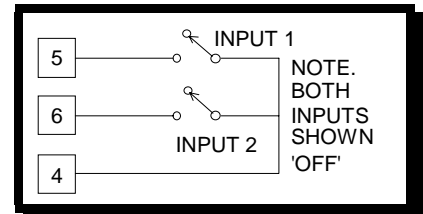

4.5 Slidewire input

If you have ordered the instrument with slidewire option then this board will be fitted. Connect the 'closed' end of the slidewire pot. to terminal (SFB CL) 27, the 'open' end to terminal (SFB OP) 25 and the slidewire pot wiper to terminal (SFB WI) 26.

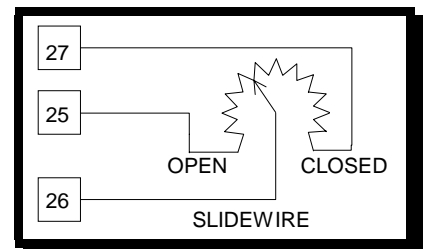

4.6 Remote Program Select Input (P3000 Only)

The remote program select input is a 0 to 10V analog signal connected into slot 3.

This may be used to select programs 0 to 24 inclusive at the rate of 0.4V per program. e.g. 0V will select program 0, 4V will select program 10 etc. This function may be performed (for programs 0 to 11) by the FGH remote program selector switch card (wired as shown). Alternatively, a 10V PLC output connected directly to terminals 19- and 20+ may be used to select programs 0 to 24.

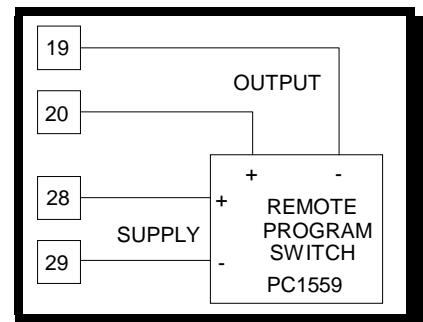

5.0 OUTPUT CONNECTIONS.

5.1 Heat/Cool

Heat and cool outputs are chosen when ordering or set up later by adding boards and configuring software. Outputs may be of time proportion relay type by using a relay board, or analogue voltage or current output by using an analogue output board.

In addition, options boards may be provided for heat only or heat and cool outputs. It is even possible to have a mixture of analogue and relay output types.

Note that all relay outputs have arc suppressing C/R networks fitted to protect the relay contacts from arc damage when changing state. This does, however, result in a small leakage current flowing through the open contacts when the relay is used to switch AC voltages (about 3mA at 240V 50Hz). This may give problems if the load is very light, e.g. a small contactor, because the small leakage current may be sufficient to hold the contactor on when it should turn off. If this problem is encountered then it is recommended that a 10k, 10W resistor be connected in parallel with the outputs load. e.g. across the coil of the contactor. The resistor will run quite hot and should be mounted in such a way that this causes no hazard.

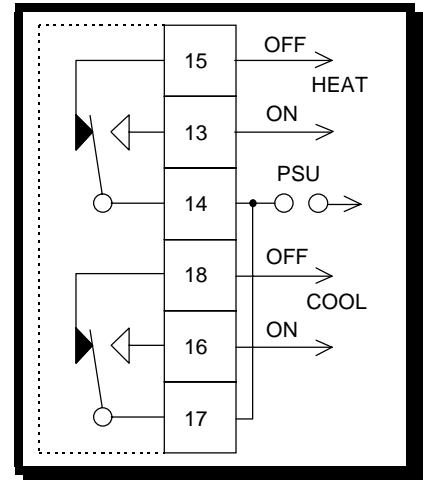

Take care not to exceed the current and voltage ratings specified for the relay output boards or damage will result.

Terminal numbers for connection of these boards are found on the label attached to the instrument case. These illustrations show common implementations.

Heat relay: H N/O, H N/C, H COM
 Cool relay: C N/O, C N/C, C COM
 Heat analogue or logic: HEAT+, HEAT-
 Cool analogue or logic: COOL+, COOL-

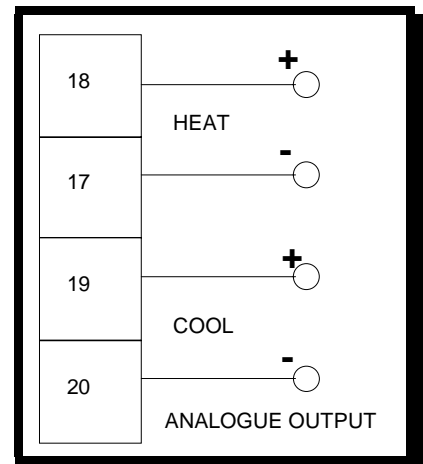

5.2 Motorised valve

Motorised valves may be driven from two relay outputs, Raise and Lower. When configured for motorised valve, the connections are as follows.

- Raise N/O: MVR NO terminal 13
- Raise N/C: MVR NC terminal 15
- Raise COM: MVR C terminal 14
- Lower N/O: MVL NO terminal 16
- Lower N/C: MVL NC terminal 18
- Lower COM: MVL C terminal 17

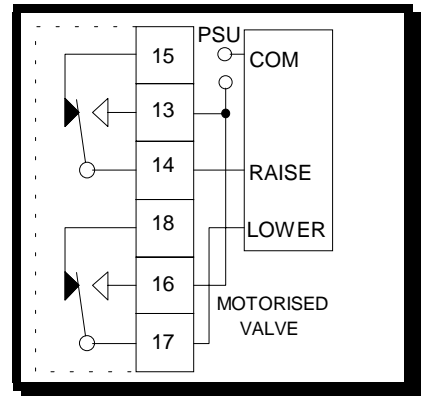

Slidewire feedback may be used if ordered, see section 4.5, or it may be omitted.

5.3 Alarms

The instrument will have up to 2 alarms with a number of relay contact outputs depending on the order placed. Connect to the terminals shown on the label stuck on the instrument case as follows.

- Alarm 1, N/O: AL1 NO
- Alarm 1, N/C: AL1 NC
- Alarm 1, COM: AL1 C
- Alarm 2, N/O: AL2 NO
- Alarm 2, N/C: AL2 NC
- Alarm 2, COM: AL2 C

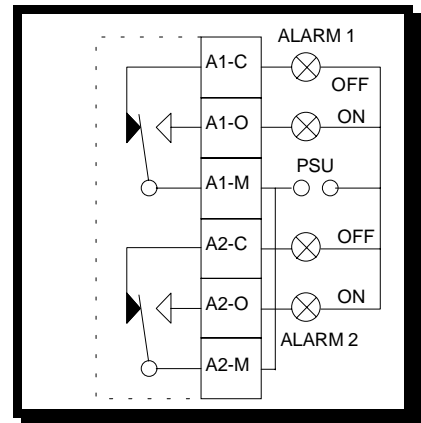

Alarm type, level, sense etc. is configured in software.

TERMINAL NUMBERS				
ALARM 1		SLOT 1	SLOT 2	SLOT 3
	N/O	13	16	21
	COM	14	17	20
	N/C	15	18	19
ALARM 2		SLOT 3	SLOT 4	SLOT 5
	N/O	21	24	27
	COM	20	23	26
	N/C	19	22	25

5.4 Retransmission

The 3000 series instrument may be fitted with analogue retransmission in slot 2 and/or slot 4. These outputs may be voltage or current outputs and this is set by means of jumper links on the output board itself.

A retransmit output fitted in slot 2 will provide its outputs on terminals (RTX1+) 18 and (RTX1-) 17.

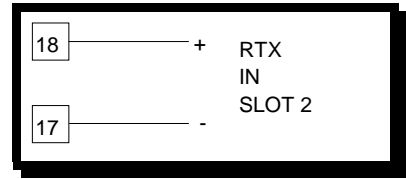

A retransmit output fitted in slot 4 will provide its outputs on terminals (RTX2 +) 22 and (RTX2 -) 23.

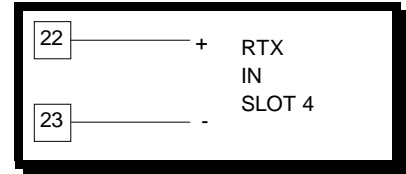

5.5 Transmitter power supply

An expanded instrument is fitted with an options carrier board which has on it slots 3 to 6 for extra functions. this options carrier board also contains the transmitter power supply. This is a supply capable of providing up to 25mA of current to power remote sensors etc. The supply is available at rear terminal 28 (TXPSU+) and terminal 29 (TXPSU-) in all expanded instruments. It is isolated from all other supplies within the instrument and decoupled to earth.

5.6 Event output (P3000 only)

Any of slots 1 to 5 may be ordered as an event output or configured later as such. Event outputs are either a relay or a logic drive output.

The numbering of event outputs is such that the lowest numbered option slot configured as an event output is made event 1, the next lowest numbered slot configured as an event output is made event 2 and so on.

Event outputs of relay type have terminals identified as EV1 NO, EV1 NC and EV1 C for event 1 and in a similar manner for events 2 to 5. A logic driver as event 1 would be identified as EV1 + and EV1 -

TERMINAL NUMBERS					
	SLOT 1	SLOT 2	SLOT 3	SLOT 4	SLOT 5
Relay					
N/O	13	16	21	24	27
COM	14	17	20	23	26
N/C	15	18	19	22	25
Logic Drive					
+	15	18	19	22	25
-	14	17	20	23	26

5.7 External event driver (P3000 only)

An expanded instrument may be fitted with an external event driver in slot 3 or 5. This allows the P3000 to be connected to a separate external event relay module which in turn provides relay outputs for all eight events. Connection to the external event driver is via two terminals, (EED +) and (EED -).

6.0 COMMUNICATIONS.

If you have ordered an instrument with communications capabilities then included with your documentation should be the booklet 'Series 3000 Communications Manual'. Read this manual for information on installing a controller with Comms.

7.0 TERMINAL LEGENDING.

Labels stuck on the top of the instrument case identify which terminals have been used and for what purpose by means of a legend printed beside each used terminal number. The following is a list of the legends used for the labels and their meanings.

AL1 NC	Alarm 1 relay output, normally closed contact
AL1 C	Alarm 1 relay output, common or wiper contact
AL1 NO	Alarm 1 relay output, normally open contact
AL2 NC	Alarm 2 relay output, normally closed contact
AL2 C	Alarm 2 relay output, common or wiper contact
AL2 NO	Alarm 2 relay output, normally open contact
C COM	Cool output relay, common or wiper contact
C N/C	Cool output relay, normally closed contact
C N/O	Cool output relay, normally open contact
COOL+	Cool analogue voltage/current output positive
COOL-	Cool analogue voltage/current output negative
COM	Serial communications, common.
DI-1	Digital input 1
DI-2	Digital input 2
DI-COM	Digital input common
EARTH	Mains earth, safety earth
EED +	External event driver output positive
EED -	External event driver output negative
EV1 NC	Event 1 relay output, normally closed contact
EV1 C	Event 1 relay output, common or wiper contact
EV1 NO	Event 1 relay output, normally open contact
EV2 NC	Event 2 relay output, normally closed contact
EV2 C	Event 2 relay output, common or wiper contact
EV2 NO	Event 2 relay output, normally open contact
EV3 NC	Event 3 relay output, normally closed contact
EV3 C	Event 3 relay output, common or wiper contact
EV3 NO	Event 3 relay output, normally open contact
EV4 NC	Event 4 relay output, normally closed contact
EV4 C	Event 4 relay output, common or wiper contact
EV4 NO	Event 4 relay output, normally open contact
EV5 NC	Event 5 relay output, normally closed contact
EV5 C	Event 5 relay output, common or wiper contact
EV5 NO	Event 5 relay output, normally open contact
EV1 +	Event 1 logic output, positive
EV1 -	Event 1 logic output, negative
EV2 +	Event 2 logic output, positive
EV2 -	Event 2 logic output, negative
EV3 +	Event 3 logic output, positive

EV3 -	Event 3 logic output, negative
EV4 +	Event 4 logic output, positive
EV4 -	Event 4 logic output, negative
EV5 +	Event 5 logic output, positive
EV5 -	Event 5 logic output, negative
H COM	Heat output relay, common or wiper contact
H N/C	Heat output relay, normally closed contact
H N/O	Heat output relay, normally open contact
HEAT+	Heat analogue voltage/current output positive
HEAT-	Heat analogue voltage/current output negative
IN 1	Main input terminal, see paragraph 4.2
IN 2	Main input terminal, see paragraph 4.2
IN 3	Main input terminal, see paragraph 4.2
LIVE	Live mains power input
MVL NC	Motorised valve, lower relay output, normally closed
MVL C	Motorised valve, lower relay output, common or wiper
MVL NO	Motorised valve, lower relay output, normally open
MVR NC	Motorised valve, raise relay output, normally closed
MVR C	Motorised valve, raise relay output, common or wiper
MVR NO	Motorised valve, raise relay output, normally open
NEUTRL	Neutral mains power input
PWR-	DC power supply input negative
PWR+	DC power supply input positive
RPROG+	Remote program select input positive
RPROG-	Remote program select input negative
RSP +	Remote set point input positive
RSP -	Remote set point input negative
RTX1+	Retransmission 1 voltage/current output positive
RTX1-	Retransmission 1 voltage/current output negative
RTX2+	Retransmission 2 voltage/current output positive
RTX2-	Retransmission 2 voltage/current output negative
RX +	Serial communications, receive positive
RX -	Serial communications, receive negative
SFB CL	Slidewire feedback input, 'closed' end of pot
SFB OP	Slidewire input, 'open' end of pot
SFB WI	Slidewire input, wiper of pot
TX +	Serial communications, transmit positive
TX -	Serial communications, transmit negative
TXPSU+	Transmitter power supply output positive
TXPSU-	Transmitter power supply output negative

