



KS 108 *easy*

Compact automation unit for industrial control and process technology

Combines control, sequencing, and operation

Comprehensive function library with integrated operator dialogs

BlueDesign® graphical engineering tool

Function block diagrams

Process graphics

Commissioning

Flexible I/O systems

RL400 and vario I/O



- ❖ Compact, robust hardware
- ❖ Touch-screen operation
- ❖ Bright TFT colour display
- ❖ Multiple interfaces: front USB, CAN, RS 232, RS 485, Ethernet
- ❖ Other interfaces optional
- ❖ Function library: controller, programmer, datalogger, trend, ...
- ❖ Simple, confident operation using ready-made operating displays and parametrizing dialogs
- ❖ Integrated graphics editor for customized displays
- ❖ Convenient tools: BlueDesign and PMATune
- ❖ Self-tuning function for PID controllers
- ❖ Access to datalogger files via USB and network
- ❖ Fast, efficient data exchange between visualization and function level
- ❖ Simple update of firmware and user program via USB stick
- ❖ Remote diagnostics via BlueDesign
- ❖ Comprehensive debugging functions in BlueDesign for testing the Engineering
- ❖ Simulation of device operation

APPLICATIONS

- Industrial furnaces
- Heat treatment plants
- Driers
- Test stands
- Process technology
- Machine building

DESCRIPTION

General

The automation unit **KS 108 *easy*** is a practice-oriented combination of:

- Industrial & process controller
- PLC
- Visualization and operation
- Measurement data recording (datalogger, trend)
- Communication.

Together with the recommended VARIO and/or RL400 input/output systems, this results in a complete automation solution.

By means of the proven function blocks of the PMA library, highly functional and reliable Engineerings are generated in the shortest time.

Automatically generated operating dialogs, arranged in a predefined menu structure, provide access to all relevant parameters and data without additional programming. This greatly reduces the time required for projecting and testing.

The pages of the standard operating menu can be called directly and at any time from user-generated process graphics.

BlueDesign support plant commissioning, maintenance, and servicing. Moreover, this tool also provides simple, online access to process data and parameters during operation.

Construction

The **KS 108 *easy*** is a highly compact device designed for mounting e.g. in control panels.

The computer core consists of a 'low power' processor, which operates without the need for active cooling.

The Engineering is stored in a non-volatile Flash memory. Thanks to this design, the device's hardware is particularly robust for a long service life.

All of the numerous interfaces are easily accessible at the rear of the unit.

An SD memory card socket at the side of the unit permits memory expansion for data acquisition purposes.

Detailed images with a resolution of 320 x 240 pixels are provided by a TFT colour display. The display features excellent readability and brightness, plus long-life background lighting.

Moreover, the resistive touch feature permits direct operation via the screen. No other operating panels or terminals are required.

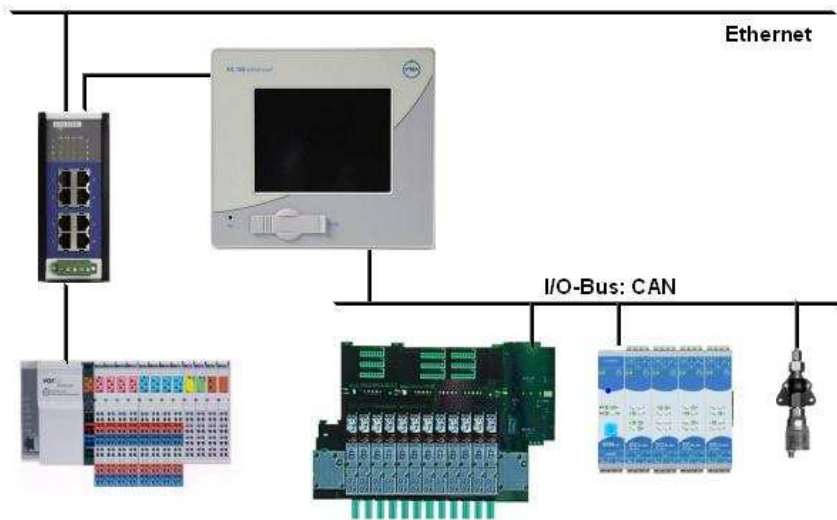

Powerful debugging functions considerably reduce the testing phase and commissioning of an Engineering.

- Online parametrization of function blocks.
- Versatile display options for process values.
- Pre-defined values for function block inputs.

User interface of the KS 108 easy

For operable function blocks, the PMA library automatically provides the associated dialogs. Moreover, the HMI editor enables freely-designed displays to be generated.

- Menus can be individually adapted to the process and to the needs of operators in numerous languages.
- Undesirable settings or switchovers are prevented by disabling certain operations in specific situations. Access is protected with a password or a control signal.
- Language selection simplifies the changeover from commissioning to the user's language (e.g. recipe names).
- Event-driven display of operating pages.
- Chaining of operating pages (e.g. programmer outputs).

Similarly, certain standard operating pages support more complex tasks:

- Operating pages of multi-output programmers are linked to the subsequent pages.
- Cascaded controller configuration is visualized by means of an overlapping operating page.
- An extension page permits every controller to be optimized.
- All alarms are displayed in a list on a separate page. Important alarms can be linked to an acknowledgement function.
- Up to 6 analog and 12 digital signals per block can be visualized above a time axis in a trend display.
- Data acquisition of up to 6 analog and 12 digital signals per block is handled by Logging function blocks. Data is stored on an SD card, and can be copied onto a USB stick.

BlueDesign graphics editor

BlueDesign is a PC-based graphics editor used to generate Engineerings. Various structuring aids are provided to improve layout transparency.

- Breakdown of the Engineering in up to 15 programs, each of which runs in a selectable cycle and with adjustable priority.
- Macros used to encapsulate repeated and established functions in a practically unlimited nesting depth.
- Export and import of macros permits the reuse of generated and tested functions in other projects.
- Within a program or macro, arbitrary function blocks can be positioned anywhere on the worksheet, and 'wired' according to their function.

- The definition of variables simplifies 'wiring' of comprehensive Engineerings, and provides access to global information.
- Lists of variables can be exported and imported in the form of text files. This enables them to be generated and modified with external text editors.

Apart from the standard operating displays, the on-board HMI editor can be used to create additional plant and process graphics to meet individual operating and display requirements.

In this way, the automation unit KS 108 easy is given a customer-specific 'look' with displays and terminology that are familiar to the operators.

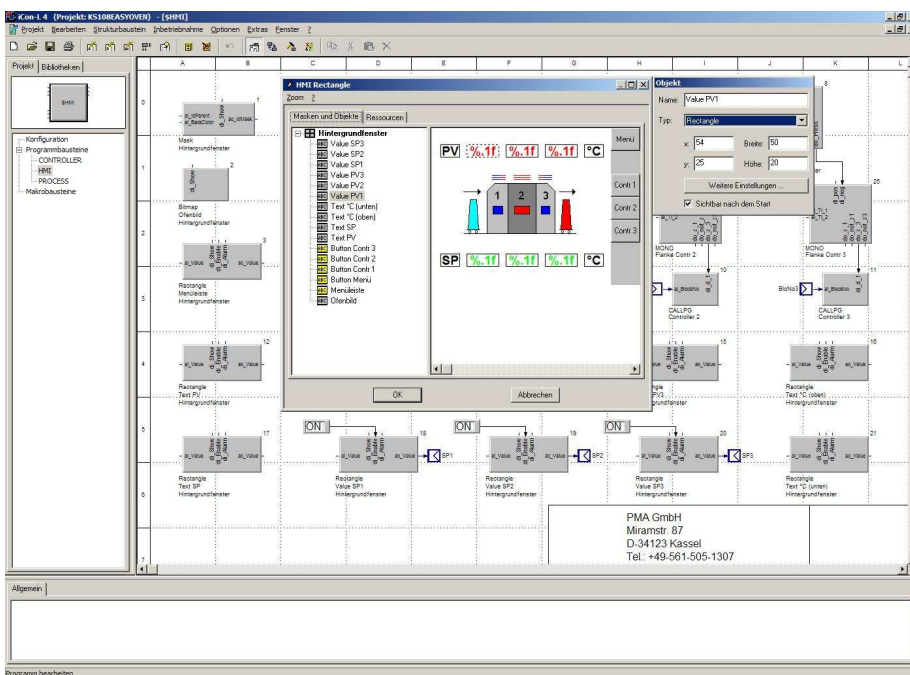

Function library

Amongst others, the library of the KS 108 easy contains functions for the following areas:

- Controllers
- Programmer
- I/O connections
- Scaling
- Arithmetic
- Logics
- Trends
- Data logging
- Alarm processing

The image below shows the 'Programmer' block with its associated operating pages and the online parameter dialog, as well as a trend display.

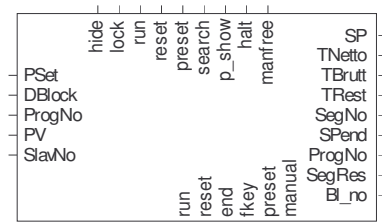

A_PROG

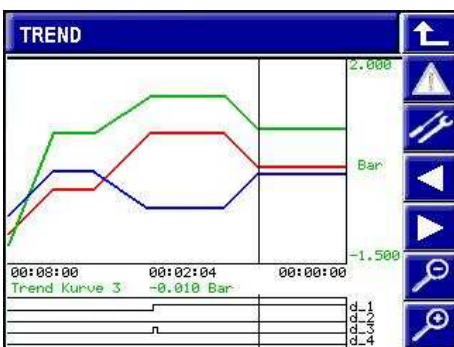
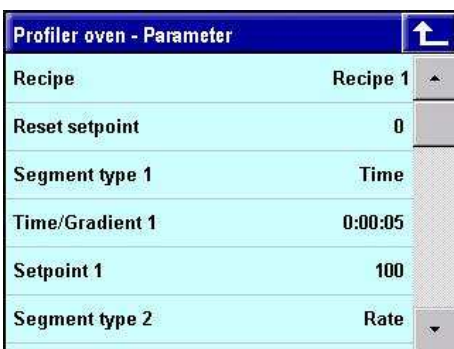

TECHNICAL DATA

PROCESSOR

CPU: Freescale Power PC / 266 MHz
 Passive cooling
 64 Mbyte RAM / 32 Mbyte free
 16 Mbyte Flash memory / 8 Mbyte free
 16 kbyte buffered RAM
 Realtime clock
 Backup: with lithium battery

DISPLAY

5,7-inch colour TFT,
 Resolution: QVGA 320 x 240 pixels
 256 colours, resistive touch operation

INTERFACES

Serial interfaces

Type: RS 232, 9 pins Sub-D connector
 Max. cable length: 12 m

Type: RS 485, 9 pins Sub-D,
 galvanically isolated,
 Max. cable length: 1000 m

CAN interface

Sub-D, galvanically isolated, 9 pins
 Cable lengths according to CANopen

Network

Ethernet port (10/100 base T),
 galvanically isolated

USB interface

USB host (Type A, in front panel)

Extensions

Socket for I/O modules
 Socket for field bus modules
 Slot for SD memory card

POWER SUPPLY

Supply voltage:
 24 VDC (18...32 V / SELV),
 galvanically isolated
 Residual ripple ≤ 4 Vpp
 Current consumption: 1 A typical, max. 2 A

ENVIRONMENTAL CONDITIONS

Permissible temperatures
 For specified accuracy: 0...50 °C
 Storage & transport: -20...70 °C

Relative humidity: max. 85 %
 no condensation

INFLUENCING FACTORS

Power supply

No loss of configuration data in case of a power supply failure (Flash EEPROM memory).

Vibration test

Sinusoidal oscillations acc. to IEC 60068-2-6 and EN 60068-2-6
 Test Fc: 10...150 Hz, 1 g

Shock test

to IEC 60068-2-27 and EN 60068-2-27
 Test Ea: 15 g for 10 ms, half sinewave

ELECTROMAGNETIC COMPATIBILITY

Immunity

In accordance with EN 61 000-6-2 and EN 61326-1, industrial

Emission test

In accordance with EN 61 000-6-4 and EN 61326-1, industrial

GENERAL

Weight

approx. 1,5 kg

Protection class

Front panel: IP 65
 Rear: IP 20

Electrical safety

Complies with EN 61010-1 and IEC 61131-2
 Over-voltage category II
 Contamination degree 2
 Protection Class III (protective low voltage)

CE marking

Fulfills the EU Directives for electro-magnetic compatibility and low voltage.

UL / cUL

Applied for

Standard accessories

Supply voltage terminal
 Mounting accessories

DELIVERY CONDITION

Every controller is delivered with a mini Engineering that explains the unit's operation on the touchscreen. Operating and safety instructions are included in the delivery.

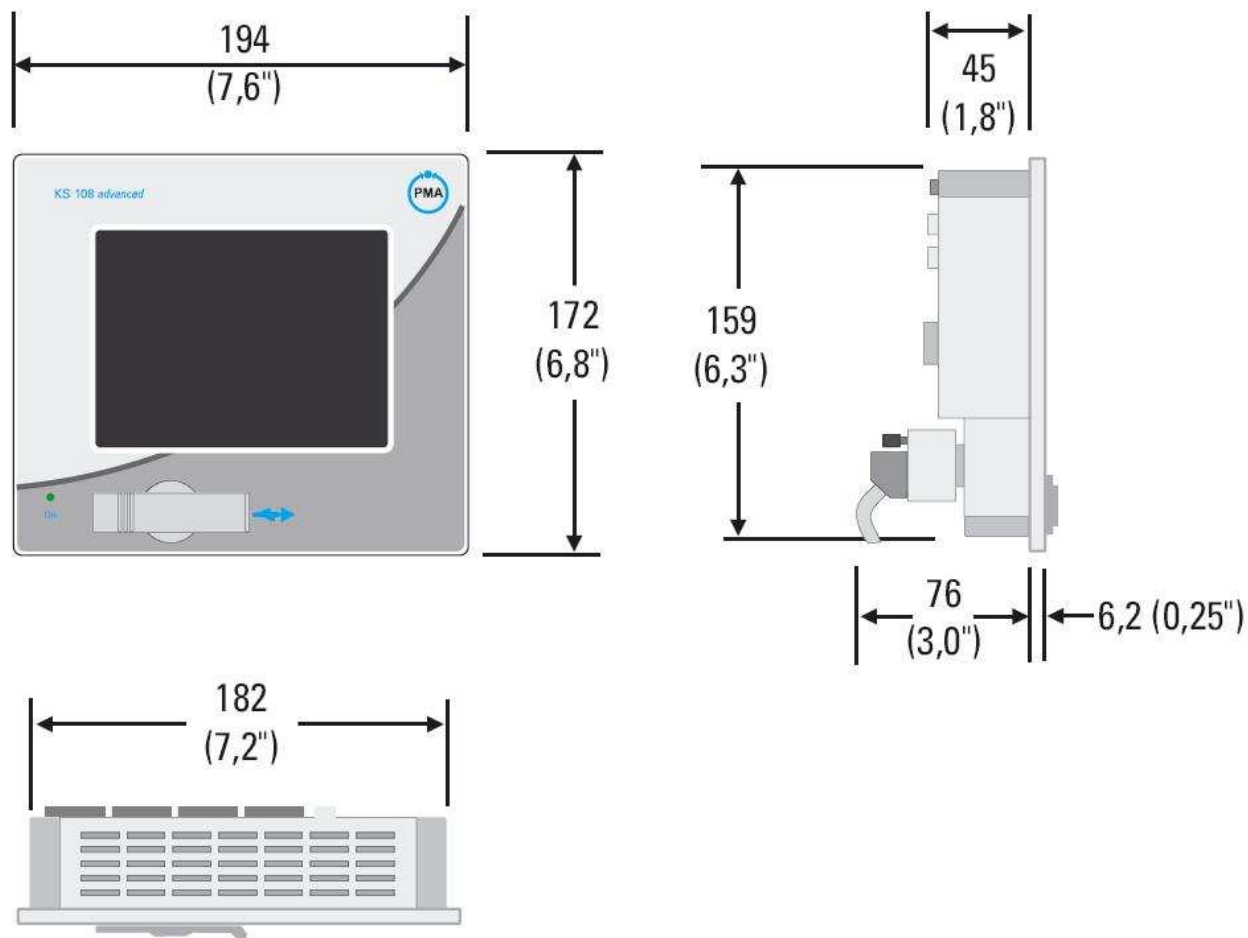

Fig. 1: Overall dimensions KS 108 easy

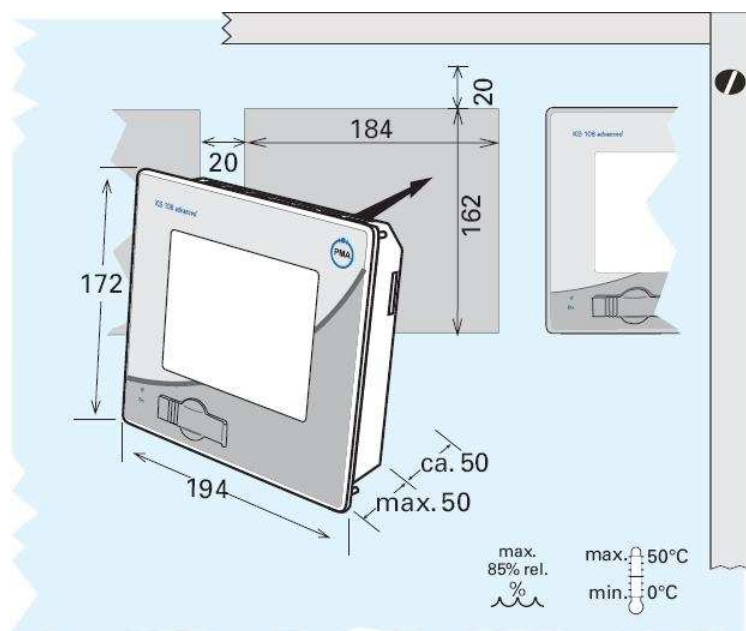

Fig. 2: Fitting dimensions KS 108 easy

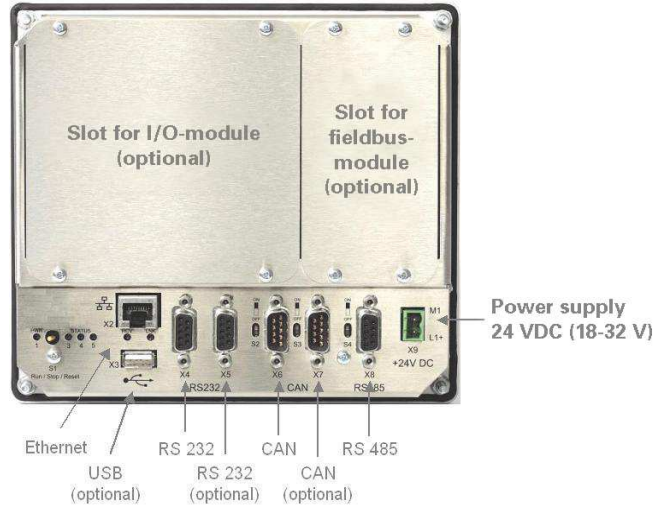
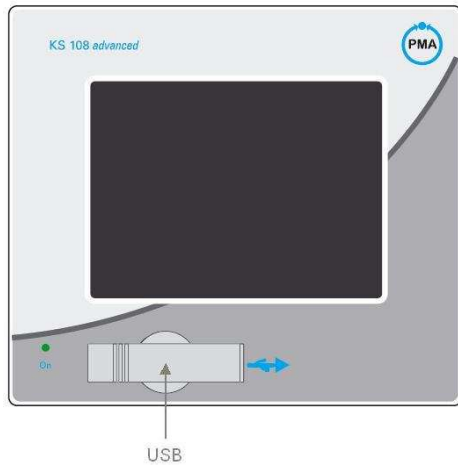

Fig. 3: Connections KS 108 easy

Ordering information

Automation unit KS 108 easy ¹	K	1	0	8	-	1	3	0	-	0	0	0	x	x	-	x	xx
PMA FUNCTION LIBRARY													↑	↑	↑	↑	
Standard													0				
SETTING																	
Standard													0				
Customer-specific													9				
APPROVALS																	
CE																0	
CE, UL/cUL (applied for)																U	
FRONT OVERLAY																	
PMA Standard																	00
Customer-specific front overlay (as of 100 pcs)																	xx

¹ TFT color display, 5,7"

Accessories

Description	Order code	Function
BlueDesign Expert	9407-999-14011	Grafical Engineering Tool and simulation program
Engineering Set (D)	9407-999-10631	Engineering manual and installation CDROM (German)
Engineering Set (E)	9407-999-10621	Engineering manual and installation CDROM (English)
8 Port ETH Switch	EDG-6528L	8 Port Industry switch for rail mounting

Recommended I/O systems

Description	Order code	Function
vario I/O	KSVC-xxx-xxxxx	See Data sheet ... (www.pma-online.de)
rail line	RL40-xxx-xxxxx	See Data sheet... (www.pma-online.de)

**PMA**

Prozeß- und Maschinen- Automation GmbH

P.O. Box 31 02 29

34058 Kassel / Germany

Tel.: +49 561 505 1307

Fax.: +49 561 505 1710

E-mail: mailbox@pma-online.de

Internet: <http://www.pma-online.de>

Your local representative: